



SHOTBLASTING MACHINES
**WIRE RODS,
BARS & BILLETS**



CYM MATERIALES S.A.
INDUSTRIAL SOLUTIONS

WIRE RODS, BARS & BILLETS

CYM Materiales SA manufactures shot blasting machines for continuous in-line descaling for steel wire industry ensuring high productivity with a low operating cost and a process that does not pollute the environment.

In-line BAR machines are designed for descaling wire rods or bars and can process in single-strand or multi-strand at the same time with high throughput speeds (more than 250 m / min.).

BAR machines also used for blasting steel billets to remove mill scale of the surface to improve the visibility prior to the crack detection process.

According to the model, the machines are equipped with between one (1) and four (4) turbines that together with abrasive concentrators ensure a correct coverage in the processed parts to cater to a varied range of operating requirements.

Blasting machine are complemented with pay-off for wire rod when the equipment is integrated with drawing lines and with external roller conveyors with automatic loading and unloading systems to process bars or billets.



FEATURES CONSTRUCTION

BLAST CABINET

- Compact design allows insertion in wire drawing lines.
- High chrome cast steel liner plates ($\geq 64Rc$) and manganese steel plates to protect
- Screw conveyor - Spiral 15b30 boron-steel
- Access doors blast cabinet for easy access maintenance.



CONCENTRATOR AND REBOUND PLATES

- Improve equipment performance on fine wires.
- Three adjustment options for deflector position: fixed, manual or pneumatic.

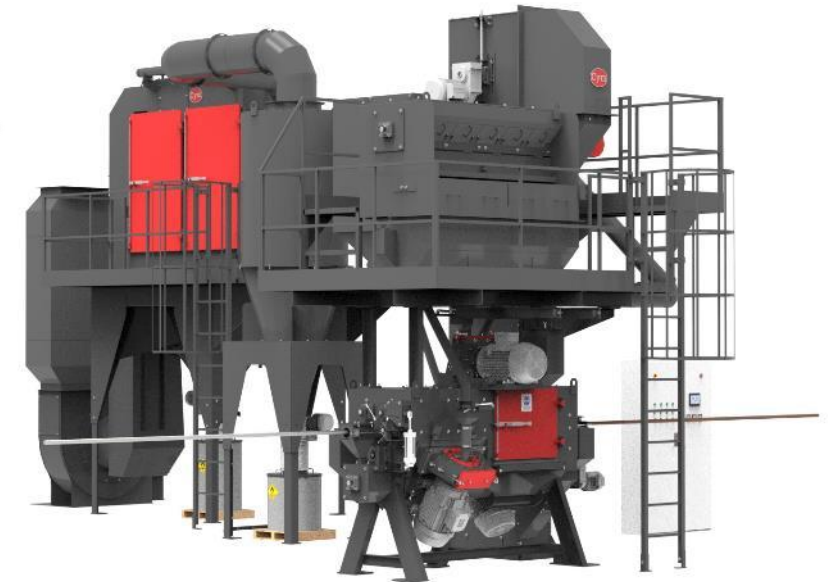
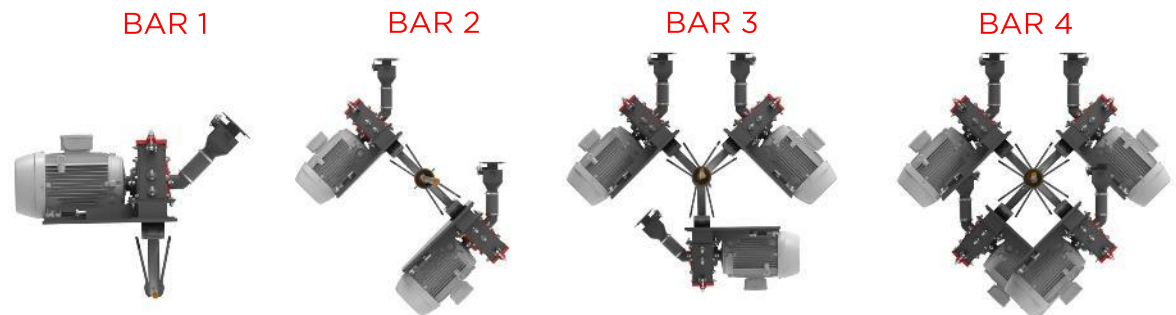

BLAST WHEEL

- Located strategically with a correct distribution of shot on the rod to be treated resulting in a better coverage and better performance of the machine.
- Direct Drive from 10 HP up to 60 HP
- Housing manufacture in MN (11-14%) steel Forming together with the internal liners and double resistant wear wall.
- High chrome steel Internal liners ($\geq 64Rc$). Liners attached by screw with hardened cast steel head cover for abrasion protection.
- Positioning and fixing system for control cage, eliminates the risk of incorrect adjustment of the hot spot.
- Labyrinth seal of abrasive between engine coupling and housing with possibility to mount the turbines in any position.

WORK CONVEYOR FOR BAR & BILLETS

- Input & output accumulator.
- Automatic loading and unloading system.
- Conveyor lengths as required.
- Variable speed control for different diameters and qualities of bar blasting

PLAY-OFF FOR WIRE ROD

- When they are integrated into wire drawing lines.
- Wire straighteners.
- Optional
 - Wilco scale breaker.

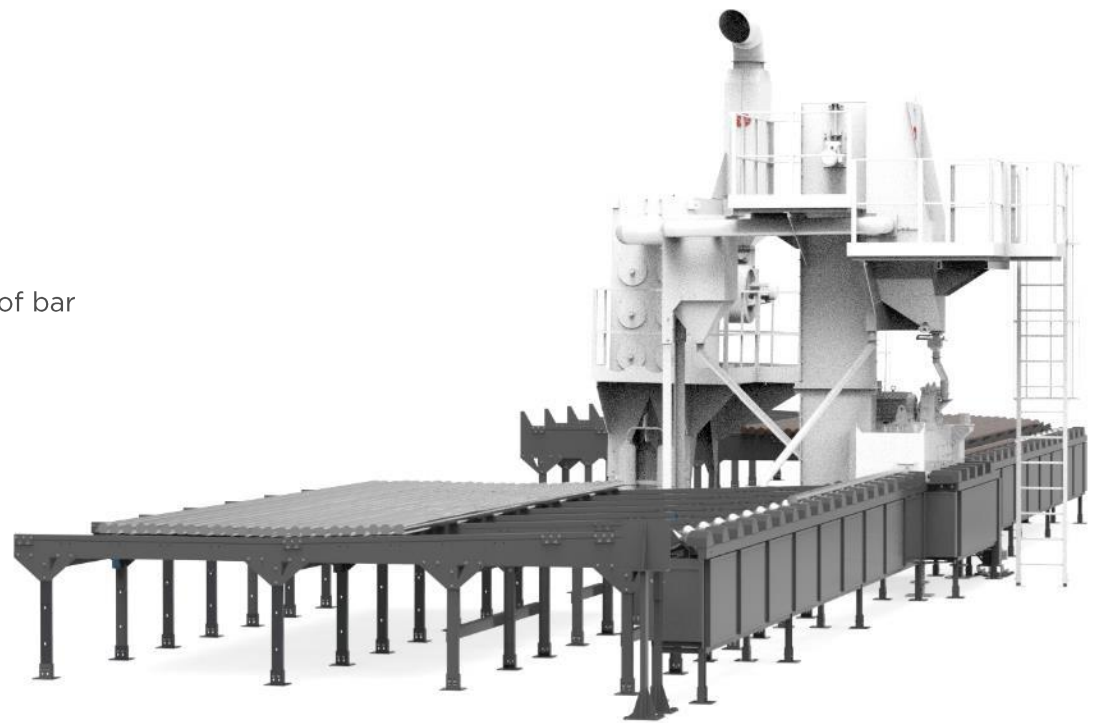

ABRASIVE RECOVERY SYSTEM

- Bucket elevator.
- High efficiency Air flow abrasive cleaning
- Upper Screw - Spiral 15b30 boron-steel
- Storage hopper for good abrasive
- Maintenance platform
- Abrasive flow control valves
- Optional
 - Automatic Abrasive Regeneration
 - Automatic abrasive curtain formation adjustment system including sensors and airflow monitoring, all controlled from the HMI

DUST COLLECTOR

- Manufactured with mild steel - 3,2 mm thick
- Cartridge media cleaning: reverse Pulse jet
- Easy replacement of cartridges
- Emission: $\leq 1 \text{ mg/m}^3$
- Efficiency $\geq 0.5 \text{ micron} / 99.9\%$
- 200L dust accumulation drum with lid transition to drum with sleeve filter
- Intermediate gravitational separator located between blast cabinet and dust collector allows for increasing the air flow inside the cabinet without risk of carrying good abrasive to the dust collector drum
- Optional
 - Silencer and Mineral wool cover kit to reduce noise $\leq 85\text{dBA}$ a 1.52m
 - Maintenance platform

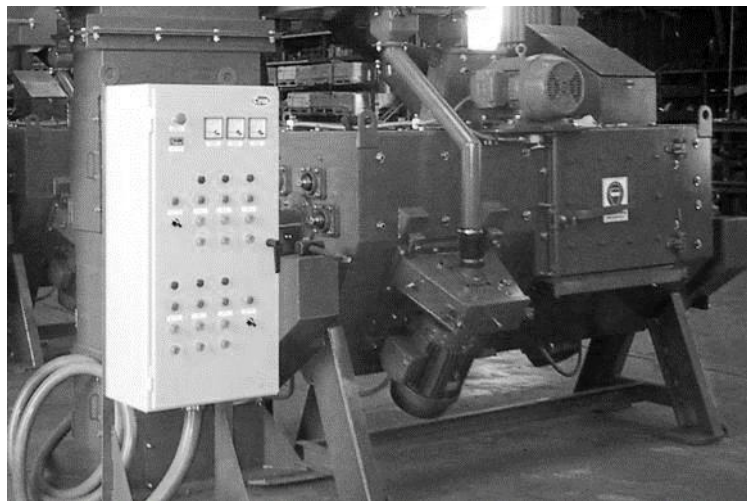
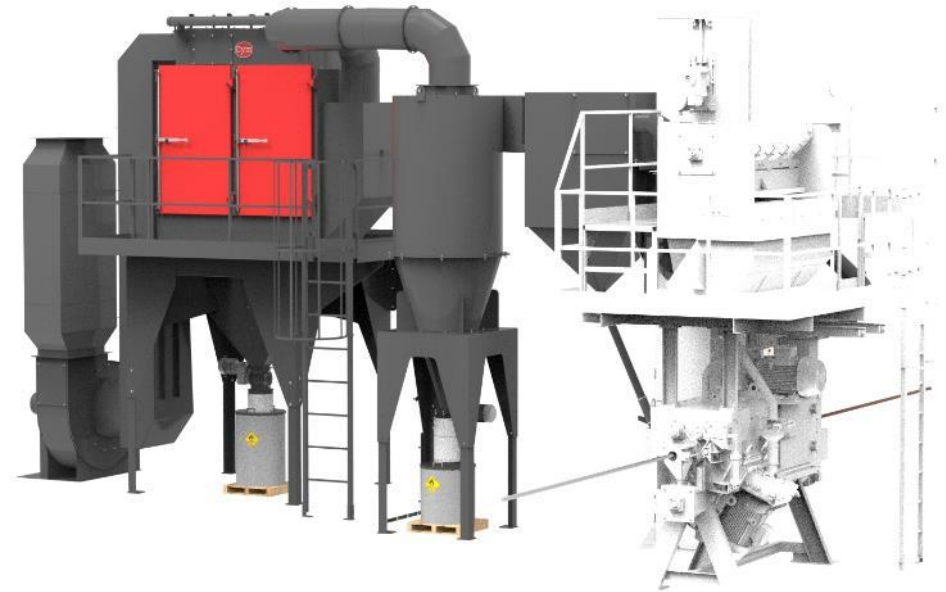

ELECTRIC COMPONENT

- Control panel for operation control
- Components and motors: according to customer requirement IEC, Nema, UL, etc.
- PLC control: Siemens
- Emergency stop button: included.
- Wire cables to connect control panel and motors.
- Total HP/Kw
 - COIL 4 - 347 HP / 260.25 Kw
 - COIL 5 - 464 HP / 348 Kw
- Optional
 - Movement sensor motors
 - Cooling
 - Soft Start motors.

TECHNICAL DATA - SHOT BLASTING FOR WIRE ROD, BAR & BILLETS - BAR

Model	Blast Wheel		Material			Section				Production m/min (*)
	Qty.	HP	Wire	Bar	Billets					
BAR 1	1	10-60	-				-	-	-	5 - 250
BAR 2	2				-					
BAR 3	3		X	X		X	X	X	X	
BAR 4	4				X					

Note

(*) The production can vary depending the diameter of rod, wire, bar and billets, degree of rust, mill scale, and or other contaminants present

(**) If the equipment you require is not in this catalog please contact our sales or engineering departments which will help to develop the best equipment to suit your needs with our goal to reduce operating costs and increase profitability in your production systems.

MECHANICAL DESCALER ADVANTAGES

- Eliminate environmental pollution problems
- Do not need facilities for the regeneration or post treatment of waste material such as those required for the treatment of chemical effluents and toxic fumes
- When the machine is operated properly they do not cause any health problems or damages to the plant as those caused by the steam released from the chemical descaling process
- Lower production costs
- Automatic shot blasting process does not require skilled labor.

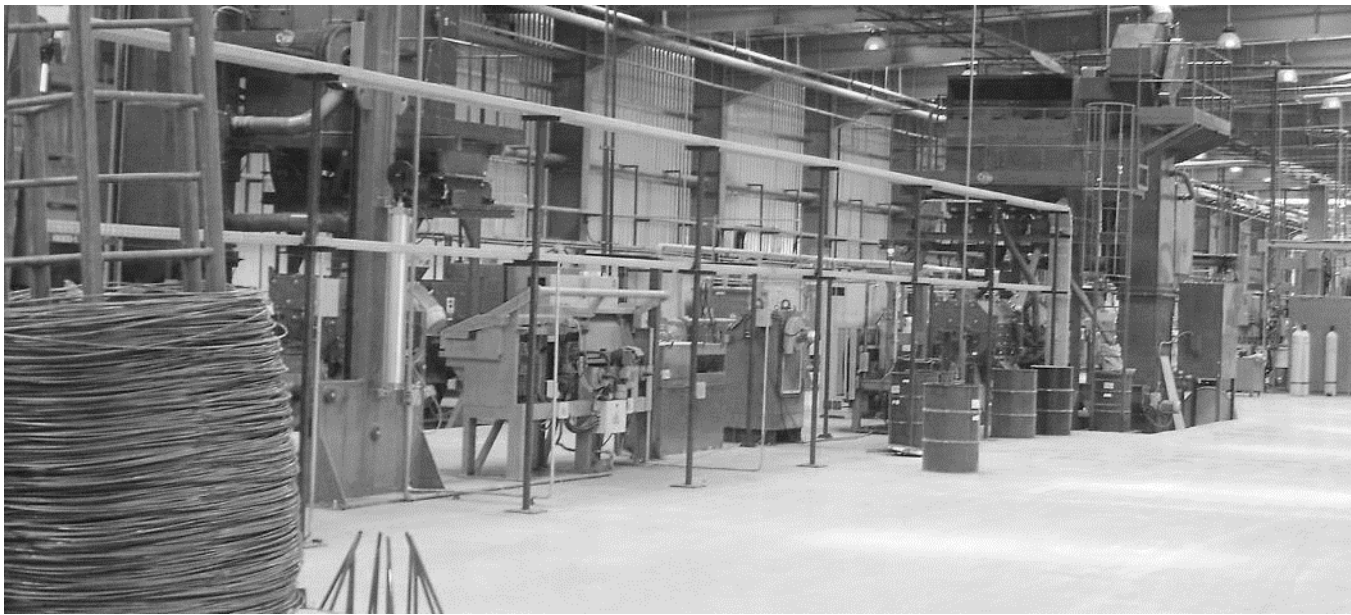

OTHER MACHINES USED IN THE WIRE DRAWING INDUSTRY

COIL SHOT BLASTING MACHINE

- The COIL shot blasting machine has been designed to process wire rods of up to 3000 kilos of weight at a time ranging from 7 to 20 minutes depending on the type of steel and diameters of wire to be treated.
- Two models of machines available, COIL4 and COIL5 with 4m and 5m mandrel and 6 and 8 turbines, respectively, ensure optimum coverage in the coil of processed wires.
- According to customer requirements, COIL equipment can have one or two mandrel loading doors. The double door machine minimizes downtime and optimizes the process.

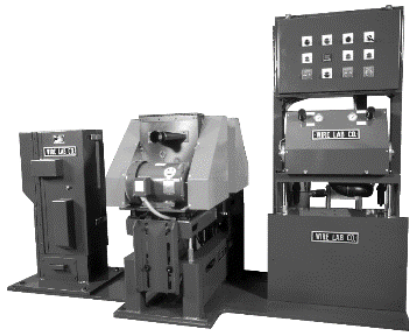
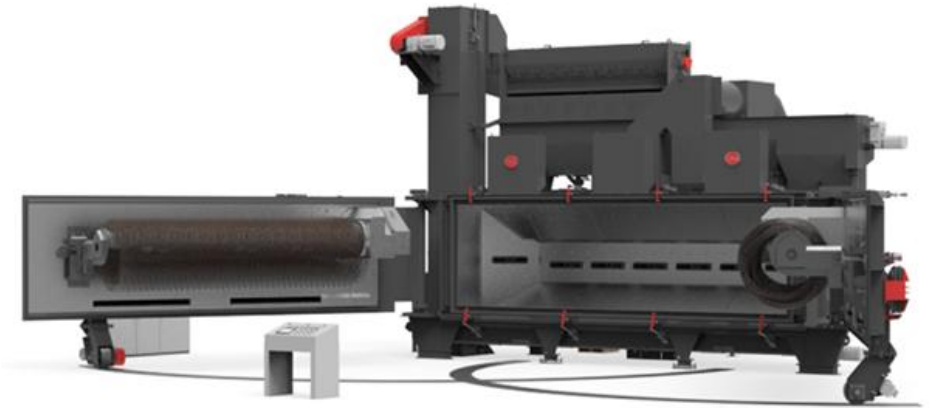

WILCO MECHANICAL DESCALERS

- Wilco system is designed to process low through high carbon rods, \varnothing 0.218 inch (5.5mm) through \varnothing 0.500 inch (12.7mm).
- Six (6) standard models of WILCO Mechanical Descaling Systems.
- Using high quality components that support years of service in wire drawing processes, significantly reducing process costs and simultaneously eliminating environmental problems associated with chemical pickling.

DUST COLLECTOR

- Used to retain dust generated in various processes of the steel industry for the manufacture of wires and bars
 - Scale generated during the mechanical descale process.
 - Fumes and gases
 - from melting furnaces
 - welding processes
 - plasma or laser cutting processes.
 - Grinding processes
- Manual vacuum kit for cleaning in the sector.



CYM MATERIALES S.A.

INDUSTRIAL SOLUTIONS



FACTORY AND HEADQUARTERS

Brig. Estanislao Lopez N° 6
[S2108AIB] Soldini - Santa Fé - Argentina

☎ +54 341 490 1100

📞 +54 9 341 515-0249

✉ info@cym.com.ar

www.cym.com.ar

