

SHOTBLASTING MACHINES TUBES



CYM MATERIALES S.A.
INDUSTRIAL SOLUTIONS

SHOTBLASTING PIPES

Cym Materiales SA presents TUB: its complete line of machines for external shot blasting of pipes used in the manufacture of gas pipelines, oil pipelines, aqueducts and other industries.

Our wide portfolio allows blasting pipes of various sizes and thicknesses, with diameters ranging from 12 mm to more than 1524 mm, adapting to the specific needs of each customer.

Thanks to its innovative design, 100% of the abrasive impacts on the surface achieving optimum performance, reaching blasting speeds of over 20 m²/minute with high power turbines.

To guarantee an efficient and safe process, the equipment is complemented with loading and unloading systems, tube accumulation beds and external conveyors for simultaneous translation and rotation.

Advantages of using automatic shot blasting equipment

- High production volume with minimum operating costs.
- Greater homogeneity of finish on processed parts.
- Automatic shot blasting process, does not require specialised labour.
- With correct operation of the equipment, there are no health problems for personnel or damage to the installations, and no environmental pollution.

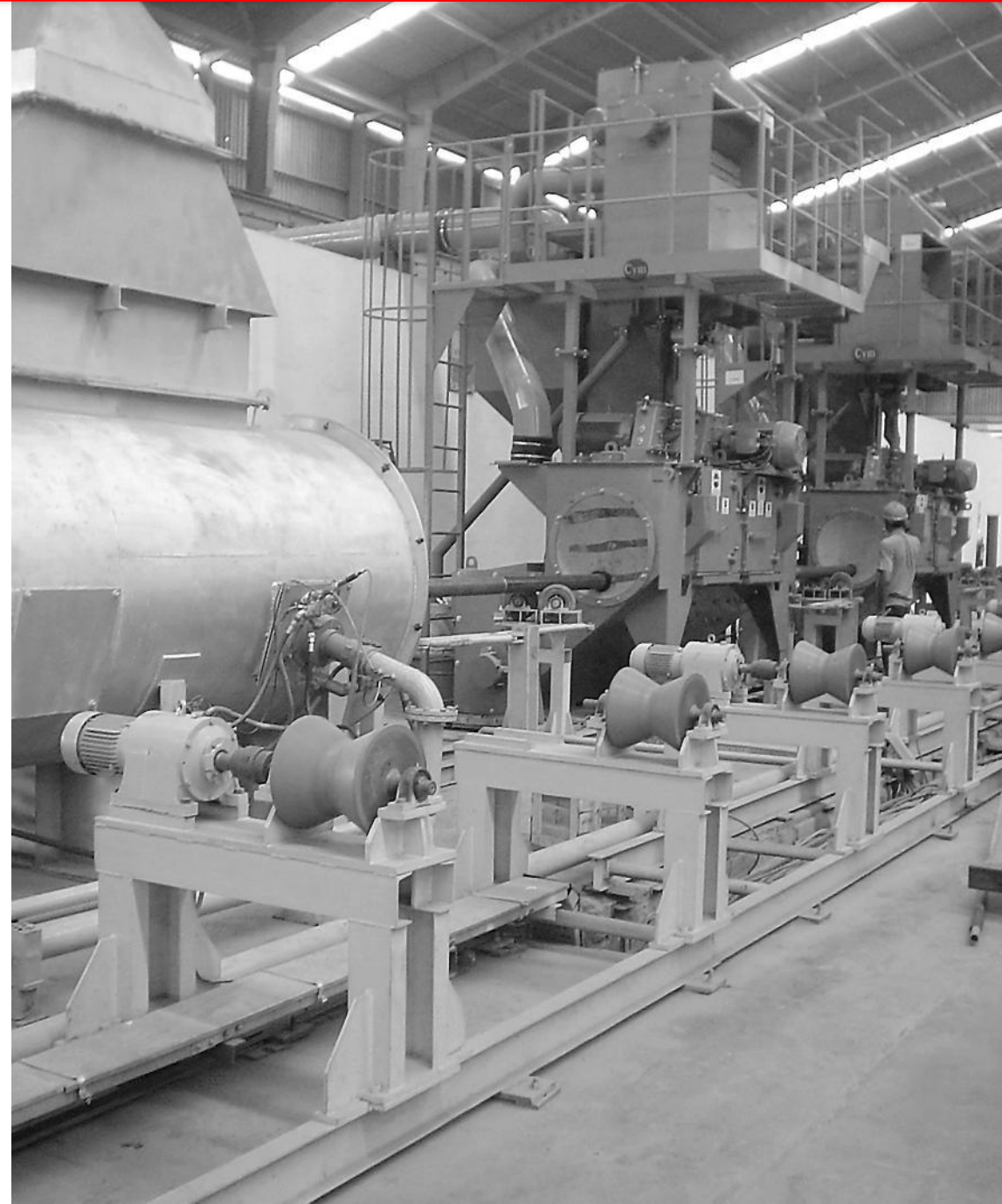

FEATURES CONSTRUCTION

BLAST CABINET

- Manufactured with triple layer of steel.
 - External in mild steel
 - Double internal protection lining
 - MN steel (11-14%) covering 100% of the main cabinet.
 - Additional reinforcement in hot areas with high chrome cast steel plates ($\geq 64Rc$)
- Screw conveyor - Spiral 15b30 boron-steel
- Access door blast cabinet
- Inlet and outlet chambers with sealing curtains to minimize abrasive escape from the blast compartment.
- Optional: Shot concentrator deflectors
 - Improve the performance of the equipment on tubes with diameters smaller than 4".
 - Three regulation options, fixed, manual or pneumatic



PARTS CONVEYOR

TUBE CONVEYOR

- Pipe infeed and outfeed accumulation bed
- Pipe loading and unloading system with hydraulic or pneumatic drives
- Conveyors with simultaneous forward and rotation system made with parallel wheels
- Conveyor lengths according to requirements
- Variable tube feed speed for different tube diameters and shot blast qualities



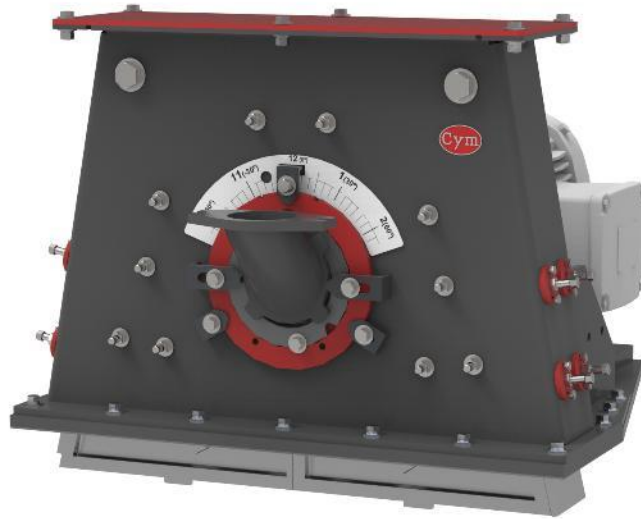

TURBINES

- Strategically located for better coverage and higher performance of the whole equipment.
- Direct coupling to the turbine engine
 - Power ratings from 10 HP to 60 HP.
- Turbine casing made of MN steel (11-14%).
- Internal casing lining made of high chrome cast steel ($\geq 64Rc$).
- Control box positioning and fixing system, allowing a correct regulation of the hot spot.
- Shot-blast labyrinth seal between motor coupling and casing, allowing the turbines to be mounted in any position.

ABRASIVE RECOVERY SYSTEM

- Bucket elevator
- High efficiency Air flow abrasive cleaning
- Upper Screw - Spiral 15b30 boron-steel
- Storage hopper for good abrasive
- Maintenance platform
- Abrasive flow control valves
- Optional
 - Automatic Abrasive Regeneration
 - Automatic abrasive curtain formation adjustment system including sensors and airflow monitoring, all controlled from the HMI

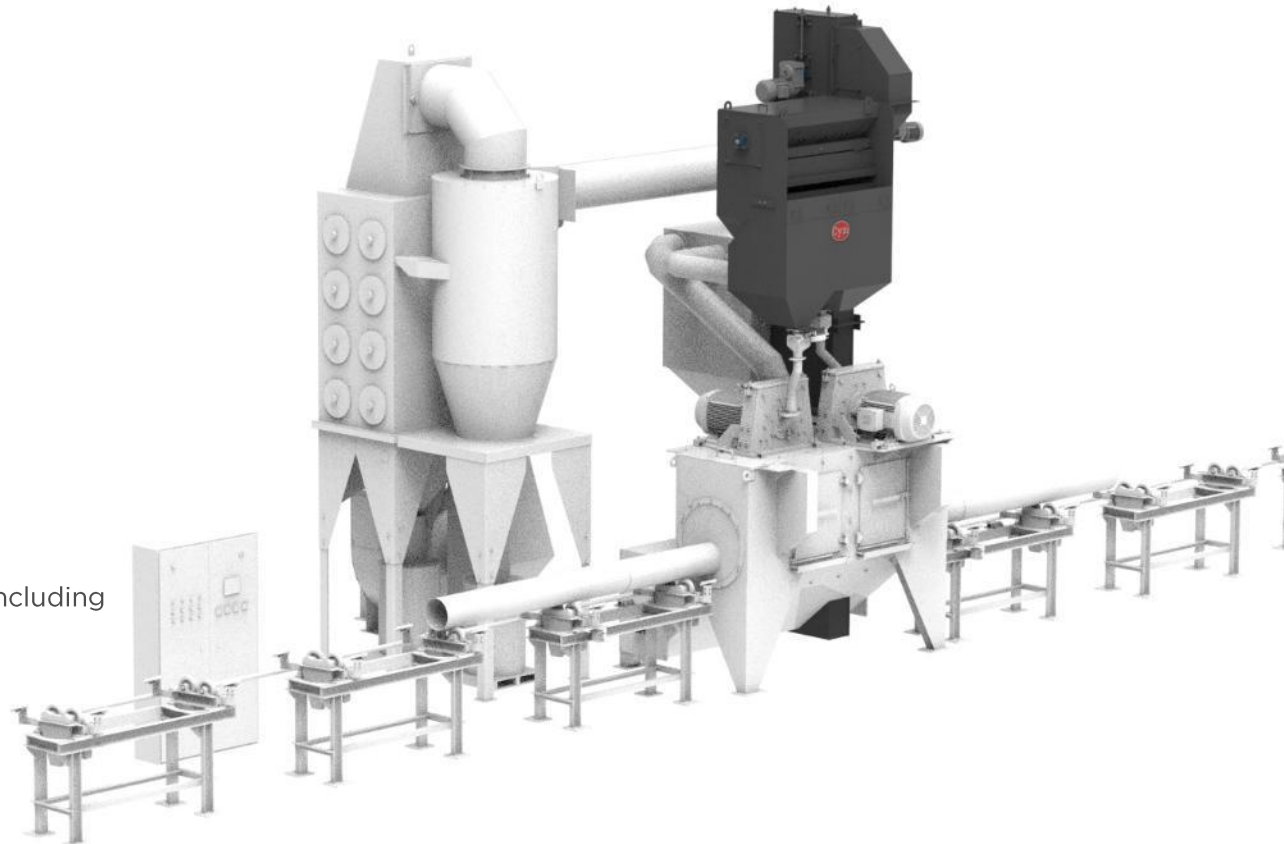

DUST COLLECTOR

- Manufactured with mild steel - 3,2 mm thick
- Cartridge media cleaning: reverse Pulse jet
- Easy replacement of cartridges
- Emission: $\leq 1 \text{ mg/m}^3$
- Efficiency $\geq 0.5 \text{ micron} / 99.9\%$
- 200L dust accumulation drum with lid transition to drum with sleeve filter
- Intermediate gravitational separator located between blast cabinet and dust collector allows for increasing the air flow inside the cabinet without risk of carrying good abrasive to the dust collector drum
- Optional
 - Silencer and Mineral wool cover kit to reduce noise $\leq 85\text{dBA}$ a 1.52m
 - Maintenance platform

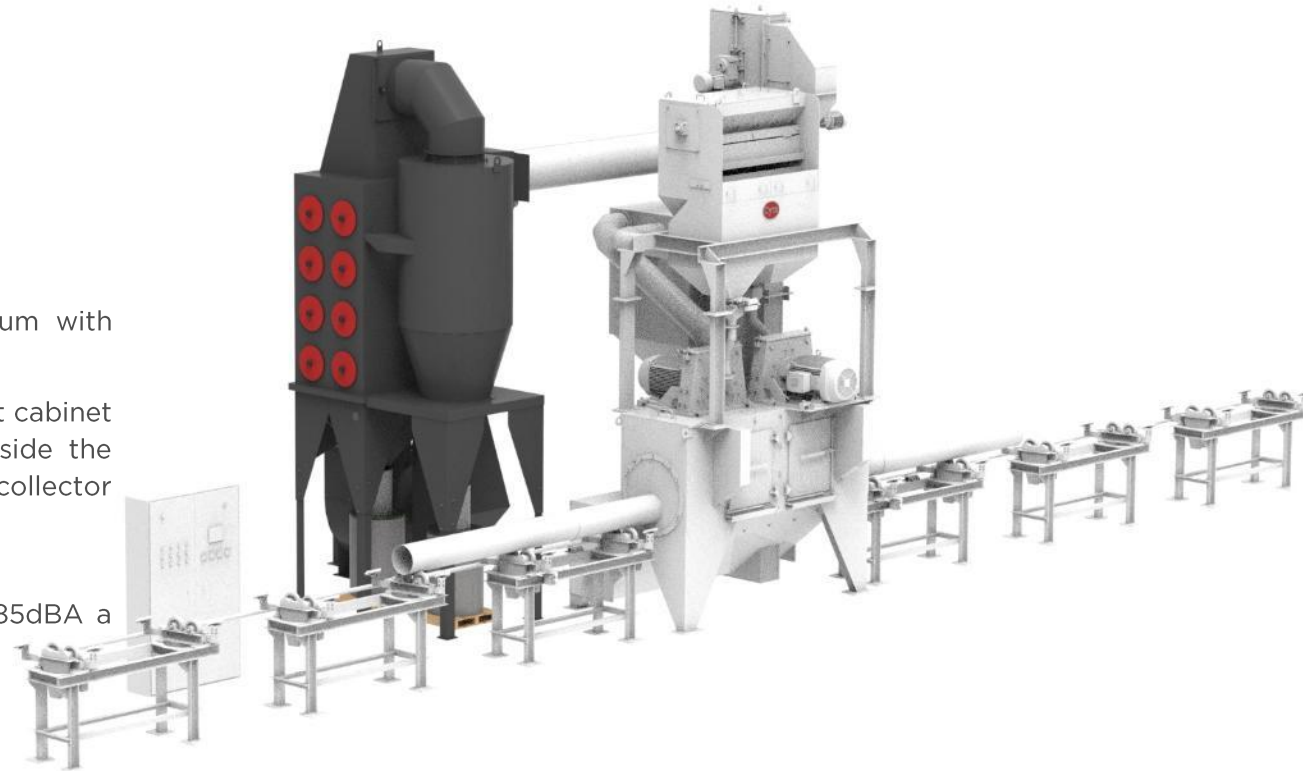

ELECTRIC COMPONENT

- Control panel for operation control
- Components and motors: according to customer requirement IEC, Nema, UL, etc.
- PLC control: Siemens
- Emergency stop button: included.
- Wire cables to connect control panel and motors.
- Optional
 - Movement sensor motors
 - Cooling
 - Soft Start motors.

TECHNICAL DATA - SHOT BLASTING FOR TUBES - TUB

Model	Turbines			Max diameter		Production m ² /min (*)
	Qty	Machine position	Power (HP)	mm	Inches	
ECO-TUB	1	Inferior	10-100	410	16	0.5 - 20
TUB 4		Superior		100	4	
TUB 12	305			12		
TUB 24	610			24		
TUB 48	Superior o Inferior			1220	48	
TUB 60	Inferior			1524	60	

Notes:

(*) The dimensions of the maximum part passage and production speed can be adapted to the customer's specific requirements.

(**) The production of the equipment varies according to the power of the turbines installed and the amount of scale, paints, oxides and degree of finishing desired in shot blasting.

MECHANICAL DESCALER ADVANTAGES

- Eliminate environmental pollution problems
- Do not need facilities for the regeneration or post treatment of waste material such as those required for the treatment of chemical effluents and toxic fumes
- When the machine is operated properly they do not cause any health problems or damages to the plant as those caused by the steam released from the chemical descaling process
- Lower production costs
- Automatic shot blasting process does not require skilled labor.

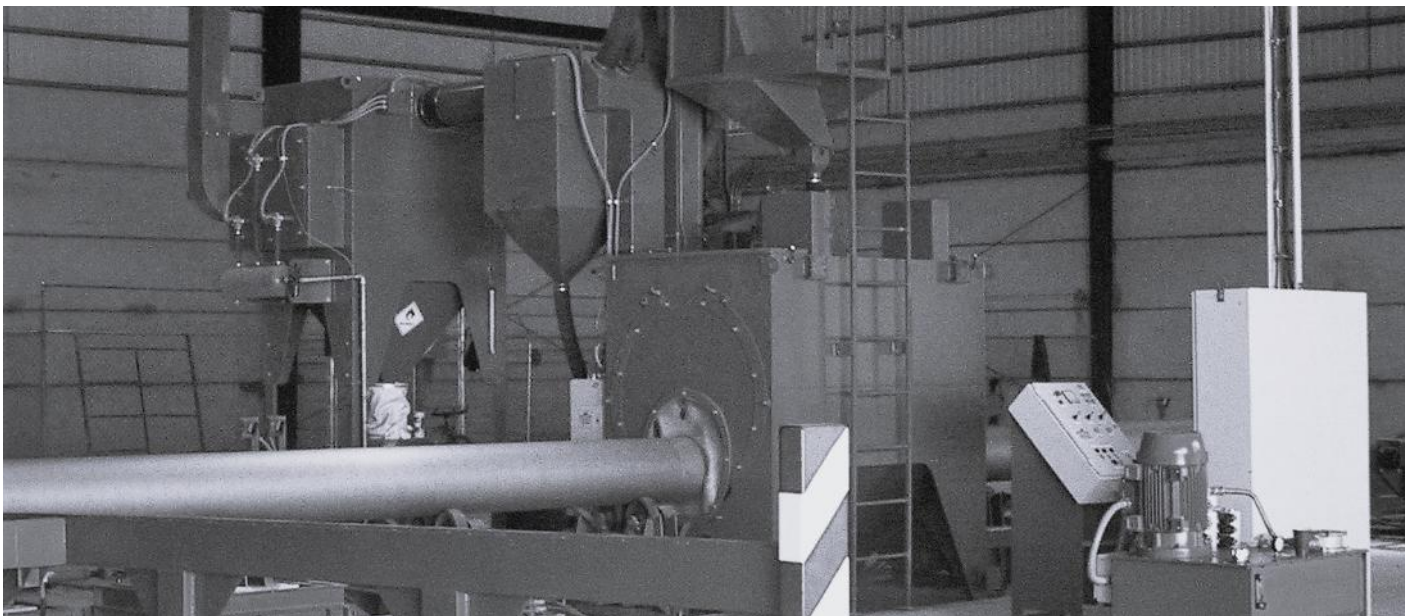

OTHER MACHINES USED IN THE STEEL INDUSTRY

SHOT PEENING MACHINE FOR THREADED PIPE CONNECTIONS

Equipment for cleaning or shot peening processes of internal and external pipe threads with abrasive impulsion by pressure or suction nozzles according to the requirements of the parts to process.



SHOT BLASTER – PER & EST LINE

Process all types of raw materials and welded structures.

Recommended for processes requiring flexibility of operation, they allow a quick set-up for processing different sizes and types of parts.

Depending on the model, the machines are equipped with 4 to 16 shot blast turbines.

The parts can be conveyed by parallel roller bed or overhead conveyors.

BLAST ROOMS

Flexible blasting process allows to process all kinds of pieces that, due to their size or complexity, cannot be processed in automatic shot blasting machines.

One or more operators are inside the blast room during the blasting process using pressure blast pot to project the abrasive.

In combination with nozzle manipulators installed in the blast room, surfaces can be automatically processed.



CYM MATERIALES S.A.

INDUSTRIAL SOLUTIONS



FACTORY AND HEADQUARTERS

Brig. Estanislao Lopez N° 6
[S2108AIB] Soldini - Santa Fé - Argentina

+54 341 490 1100

+54 9 341 515-0249

info@cym.com.ar

www.cym.com.ar

OFFICE BUENOS AIRES

Eizaguirre 1073

[B1754FLA] San Justo - Buenos Aires - Argentina

+54 11 3979-4111

+54 9 11 3345-8578

+54 9 11 2630-8077

cymba@cym.com.ar