

SURFACE PREPARATION
SPINNER HANGER



CYM MATERIALES S.A.
INDUSTRIAL SOLUTIONS

SPINNER HANGER SHOT BLASTING MACHINES

CYM Materiales SA manufactures spinner hanger shot blasting machines for batch and continuous process for a wide industrial range of products.

Spinner hanger are versatile since they allow processing different kinds of components, such as small and sensitive parts as well as more complex parts which may be heavy or large and therefore not suitable for tumbling in tumblast machine.

The hook inside the blasting chamber passes in front of the turbines, exposing the parts to the blasting stream. The rail where the hooks are mounted of different design depending on the application. Besides the rail system with one hook per rail there is also the Y track system with two hooks and an oval unit with multiple hook and continuous overhead rail blast machines.

The abrasive is propelled by centrifugal turbines using one or multiple turbines depending on the size of the blasting machine and the components to be blasted.

MAIN USES AND APPLICATIONS

- Desanding of castings in ferrous metals and nonferrous.
- Surface preparation for paint, metallic, rubber, etc. applications.
- Pickling of forged parts or heat-treated parts.
- Deburring of metal and non-metal parts.
- Elimination of oxides and flakes.
- Shot peening processes.



FEATURES CONSTRUCTION

BLAST CABINET

- External structure with robust and compact design made of SAE1010 steel
 - Different combinations of internal lining of the working chamber using the following materials
 - Abrasion resistant rubber
 - High Cr cast steel plates ($\geq 64\text{Rc}$)
 - MN Steel Plates (11% -14%)
 - Entry / exit of hooks
 - Double leaf door with manual or pneumatic opening
 - Sliding door with motorized opening
 - Rubber curtains for continuous process
 - Bottom auger with hardened steel turns
 - Pneumatic lid for closing hook passage groove
- groove



BLAST WHEEL

- Located strategically with a correct distribution of shot on the rod to be treated resulting in a better coverage and better performance of the machine.
- Direct Drive from 10 HP up to 60 HP.
- Housing manufacture in MN (11-14%) steel Forming together with the internal liners and double resistant wear wall.
- High chrome steel Internal liners ($\geq 64Rc$). Liners attached by screw with hardened cast steel head cover for abrasion protection.
- Positioning and fixing system for control cage, eliminates the risk of incorrect adjustment of the hot spot.
- Labyrinth seal of abrasive between engine coupling and housing with possibility to mount the turbines in any position.

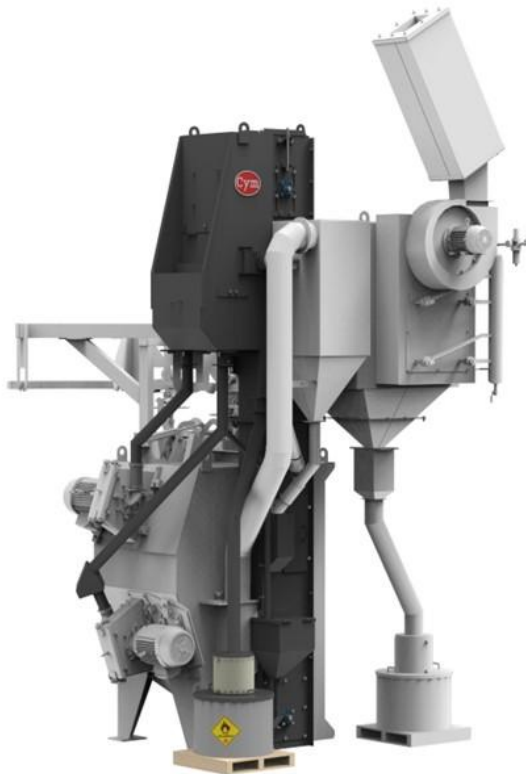
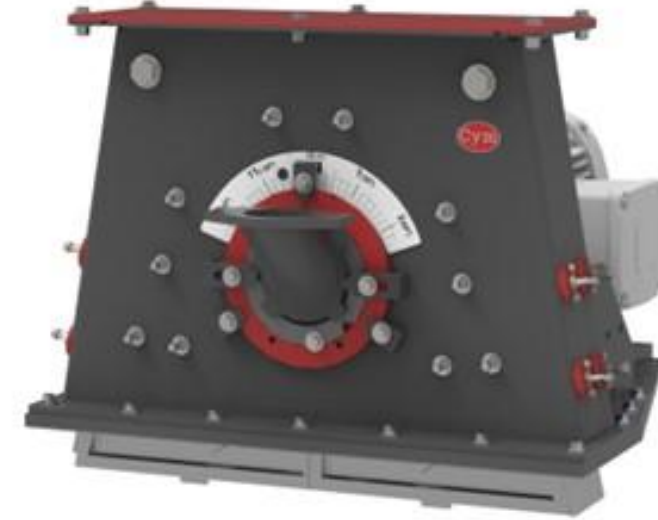

ABRASIVE RECOVERY SYSTEM

- Bucket elevator
- High efficiency Air flow abrasive cleaning
- Upper Screw - Spiral 15b30 boron-steel
- Storage hopper for good abrasive
- Maintenance platform
- Abrasive flow control valves
- Optional
 - Automatic Abrasive Regeneration
 - Automatic abrasive curtain formation adjustment system including sensors and airflow monitoring, all controlled from the HMI

UPPER HOOK

FIXED HOOK ON CEILING OR DOORS

CAB GF
Fixed Hook

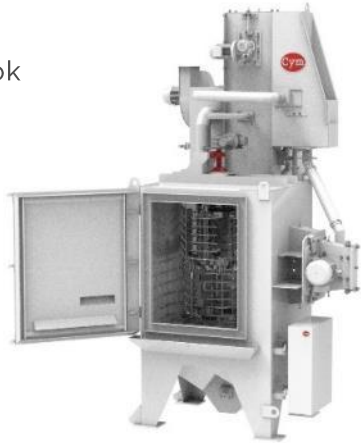

CABTAM 2P
Double door

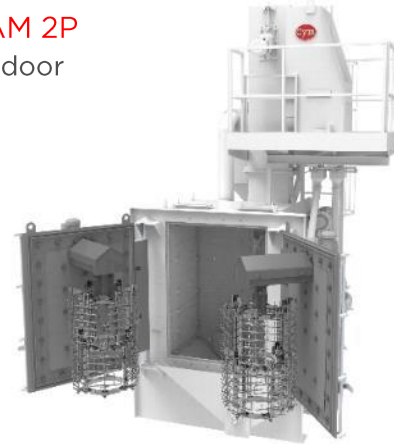

Optional Equipment with fixed hook on the ceiling or door:

- Variable Hook Rotation Speed
- Parts loading hangers

HOOK WITH MOVEMENT ON RAILS

CAB I
Mobile Hook



CAB Y
Double Hooks



CAB OVAL
Multiple Hooks

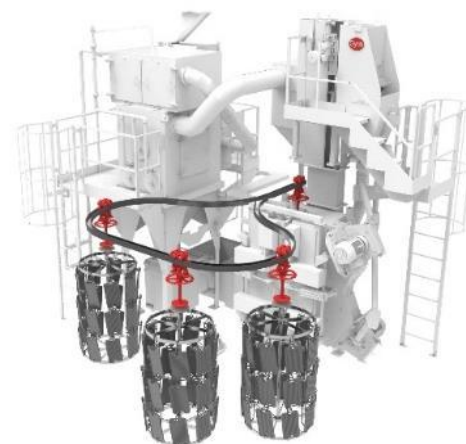

Optional Equipment with mobile hook on rails

- Movement of manual or electric hooks,
- Variable hook rotation speed
- Hook displacement in front of the shot beam

DUST COLLECTOR

- Manufactured with mild steel – 3,2 mm thick
- Cartridge media cleaning: reverse Pulse jet
- Easy replacement of cartridges
- Emission: $\leq 1 \text{ mg/m}^3$
- Efficiency $\geq 0.5 \text{ micron}$ / 99.9%
- 200L dust accumulation drum with lid transition to drum with sleeve filter
- Intermediate gravitational separator located between blast cabinet and dust collector allows for increasing the air flow inside the cabinet without risk of carrying good abrasive to the dust collector drum
- Optional
 - Silencer and Mineral wool cover kit to reduce noise $\leq 85\text{dBA}$ a 1.52m
 - Maintenance platform

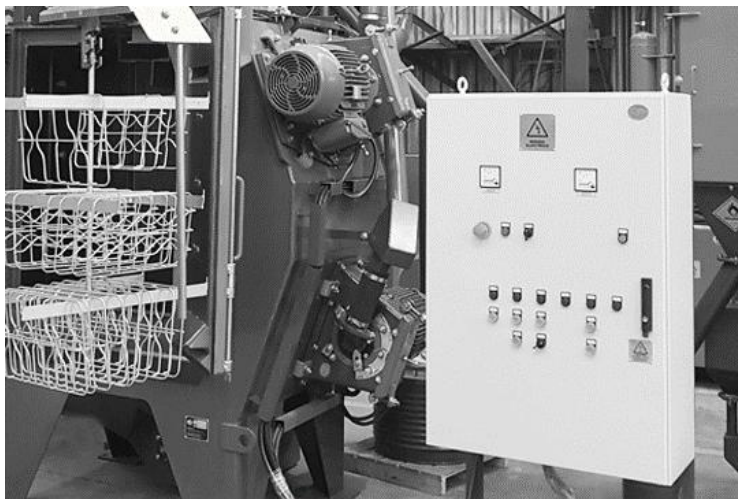
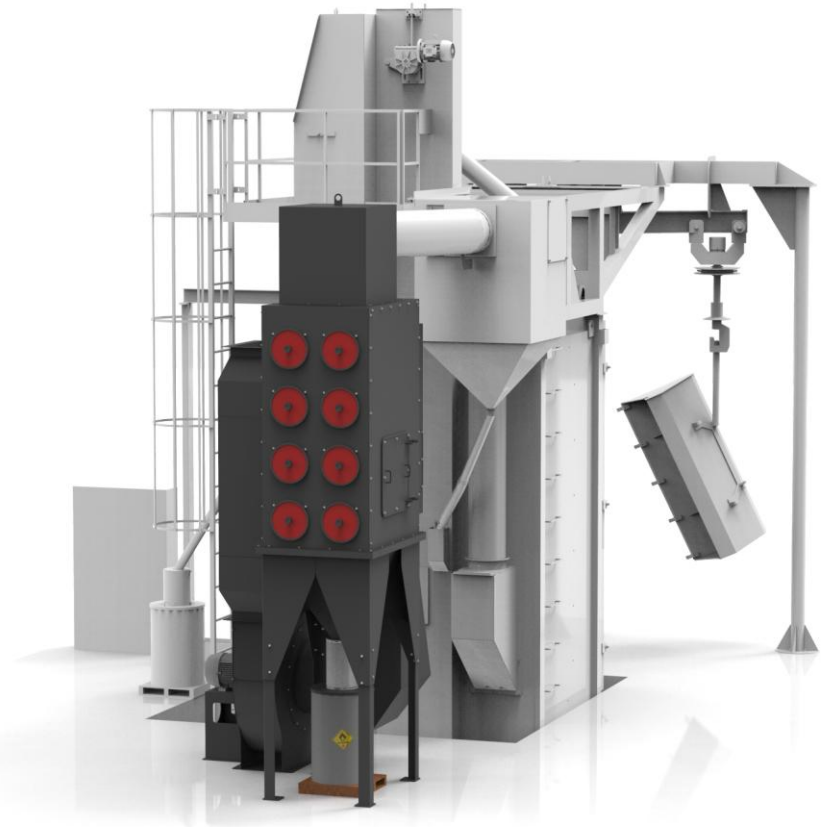

ELECTRIC COMPONENT

- Control panel for operation control
- Components and motors: according to customer requirement IEC, Nema, UL, etc.
- PLC control: Siemens
- Emergency stop button: included
- Wire cables to connect control panel and motors
- Optional
 - Movement sensor motors
 - Cooling
 - Soft Start motors

TECHNICAL DATA - SPINNER HANGER BATCH TYPE - CAB

Models	Blast Wheel			Loading Capacity		
	Qty.	Power		Kgs (*)	Diameter (mm)	High (mm)
		HP	Kw			
CAB 8X8	2	5.5 to 60	4.1 to 45	According to customer's requirement	800	800
CAB 8X14					800	1400
CAB 12X14					1200	1400
CAB 14X16	3	5.5 to 60	4.1 to 45		1400	1600
CAB 14X20					1400	2000
CAB 18X18					1800	1800
CAB 20X30	4	5.5 to 60	4.1 to 45		2000	3000
CAB 25X35	5				2500	3500

ADVANTAGES OF USING CYM SHOT BLASTING MACHINES

- Allow to process all kind of pieces, high volume with low cost.
- Excellent homogeneity of completion in the processed parts.
- Automatic process does not require specialized labor.
- Using continuous air conveyor allows to process parts in suspended load in line with painting processes.
- It does not contaminate the environment

Note:

(*) The maximum parts pass size section and the production speed can be adapted to the customer precise requirement.

(**) The production can vary depending on the degree of rust, mill scale, and or other contaminants present

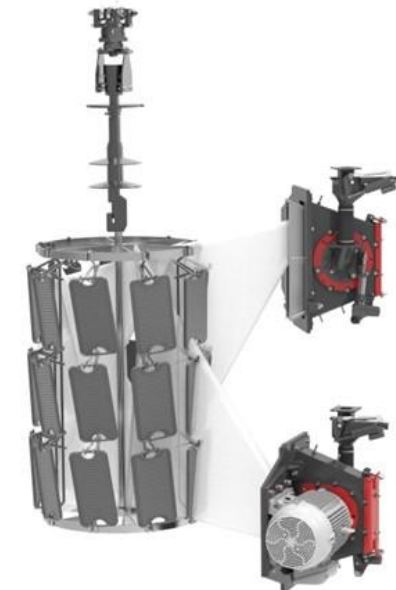
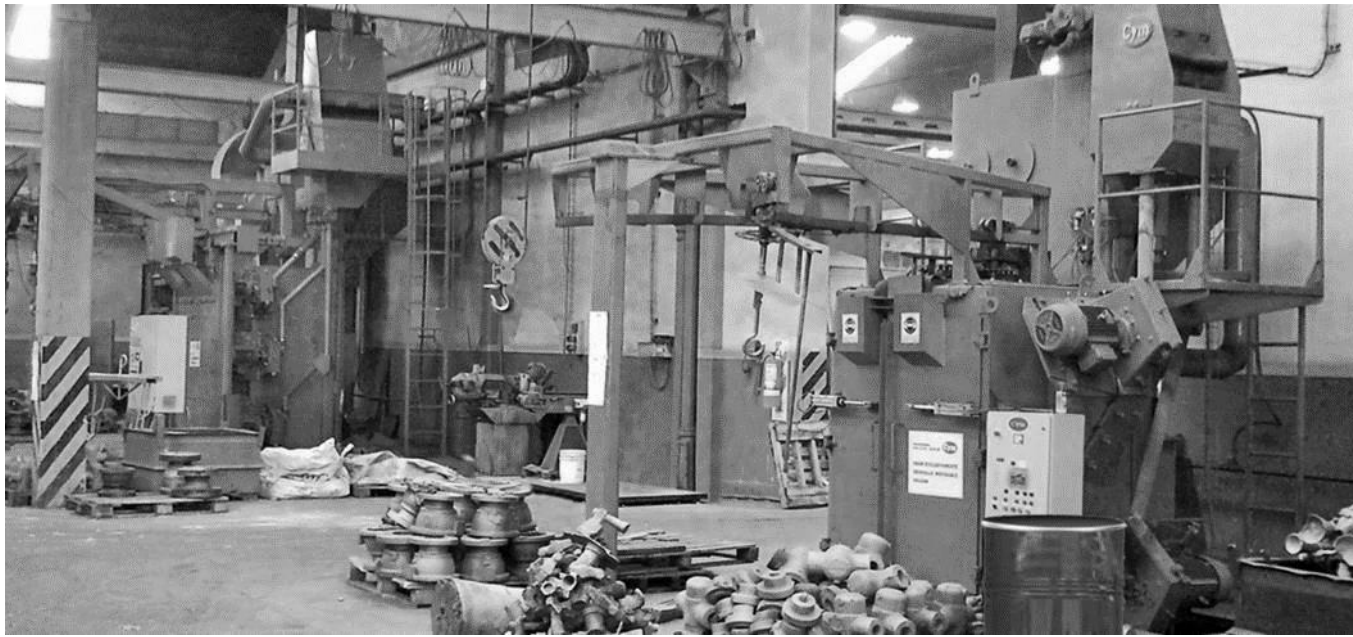

CYM MATERIALES S.A.

INDUSTRIAL SOLUTIONS



FACTORY AND HEADQUARTERS

Brig. Estanislao Lopez N° 6
[S2108AIB] Soldini - Santa Fé - Argentina

+54 341 490 1100

+54 9 341 515-0249

info@cym.com.ar

www.cym.com.ar